

Voice over LTE via Generic Access (VoLGA) A Whitepaper - August 2009

V 1.0

Table of Contents

1 Executive Summary.....	2
2 VoLGA Overview.....	3
3 Handover.....	7
4 Quality of Service.....	8
5 International Roaming.....	9
6 Emergency Calls.....	10
7 Present and Future Alternatives.....	11
8 Summary, Conclusion and Acknowledgments.....	12
9 List of Abbreviations For Easy Reference.....	14

1 Executive Summary

The Move to Packet Switched Wireless Networks

With the quickly rising use of mobile telecommunication networks for broadband Internet access, network operators and telecommunication vendors decided that it was time to define and implement next generation network technologies to keep up with the demand. The most widely adopted next generation standard is referred to as LTE, or Long Term Evolution. LTE is a project of the Third Generation Partnership Project (3GPP¹) and offers an upgrade path for all major third generation wireless network technologies. Based on the Internet Protocol (IP), it fully leverages the flexibility of packet switching and follows the path taken in fixed line networks with DSL, cable and fiber to the home deployments.

No Native Voice and SMS in LTE

While packet switched wireless networks have many advantages, there is also a major disadvantage: Voice calls and SMS messaging, the main revenue generators of mobile network operators, are no longer available in LTE, as they are based on a circuit switched radio and core network infrastructure. To counter this issue, 3GPP has so far adopted two different approaches:

- **Fallback to 2G or 3G for Voice**

The first solution, designed to be available early on, is referred to as Circuit Switched Fallback (CSFB). As the name implies it allows mobile devices to fall back to 2G or 3G networks for circuit switched services such as voice calls. The main problems with this approach are longer call setup times which result in a significant degradation of the user experience and the necessity for software upgrades on circuit switched network nodes such as the Mobile Switching Centers (MSCs).

- **IMS As a Potential Solution For the Mid and Long Term**

A solution envisaged for the mid and long term is to introduce network operator based voice services in LTE with the IP Multimedia Subsystem (IMS). Development of this fully IP based platform for rich media communication including voice calls begun many years ago for UMTS. Recently, enhancements have been specified for handing-over ongoing IMS based voice calls to circuit switched networks such as GSM when the user leaves the UMTS or LTE coverage area during a call. Due to the significant complexity of the system, however, it is likely that it will still take several years before large scale commercial IMS deployments will be undertaken.

Voice over LTE via GAN

A third solution, which this paper will focus on, is Voice over LTE via Generic Access Network, or VoLGA for short, which is defined by the VoLGA forum². Here, the concept is to connect the already existing Mobile Switching Centers to the LTE network via a gateway. As no fallback to a legacy network is required, call setup times are not increased and the user's quality of experience is consistent with that of the 2G or 3G voice environment.

VoLGA is based on the existing 3GPP Generic Access Network (GAN) standard, which is deployed for example by T-Mobile in the US and Orange in France. The purpose of GAN is to extend mobile services over a generic IP access network. One of the popular applications of GAN is with Wi-Fi-enabled phones. With GAN-based dual-mode mobile phones, all services are either available over their GSM networks as usual, or over Wi-Fi at home or in public places. Moving between the two network technologies is fully transparent to the user.

On the network side, VoLGA only requires software enhancements to the circuit to packet gateways which already exist for GAN. No modifications are required on the Mobile Switching Centers or the LTE core and access network nodes. This enables a rapid development and market introduction, especially in multi-vendor MSC network environments. Furthermore, VoLGA enables the use of all other circuit switched services over LTE without any modifications in the network. One of these applications is the short message service (SMS), which is not only a significant revenue generator but also an important tool for mobile device provisioning over the air and a requirement of the European Union for informing subscribers about voice and data charges while they are roaming in another country.

On the mobile device side, the protocol stack initially developed for GAN can also be re-used in large parts. The two main software additions required are to include the LTE access technology as a radio bearer together with a modified handover procedure, as the VoLGA approach allows for a smooth handover of ongoing voice calls to GSM or UMTS when the subscriber leaves the LTE coverage area.

VoLGA also enables a smooth introduction of global LTE roaming. If supported by the visited network, all services can be delivered via the VoLGA circuit to packet gateway and the Mobile Switching Centers in the visited network. In case VoLGA is not supported, the VoLGA gateway and the Mobile Switching Centers in the home network may be used instead, although this is currently not described in the specification. While the benefits for the user are obvious, this flexibility is also very useful from the network operator's point of view as it allows delivery of crucial services such as mandatory information on roaming charges via SMS while roaming.

The following chapters will now go into more details and show how VoLGA will work in practice from a technical point of view.

2 VoLGA Overview

Origins

The roots of 'Voice over LTE via GAN' (VoLGA) are the 3GPP Generic Access Network (GAN) specifications which add Wi-Fi as an access technology to 3GPP based networks such as GSM and UMTS. GAN requires dual mode mobile devices which have both a GSM/UMTS radio interface and a Wi-Fi radio interface. Such mobile devices are available today from a number of manufacturers including Samsung, Nokia, Sagem, LG, HTC³, Motorola⁴, Sony-Ericsson and RIM (Blackberry)⁵. When these dual-mode devices detect the availability of a suitable Wi-Fi network, e.g. at home or a public hotspot, they connect to the Wi-Fi access point and register with the GSM/UMTS core network over the Wi-Fi link and the Internet. A GAN gateway securely connects a subscriber to the infrastructure of a network operator and voice calls and other circuit switched services such as SMS are then securely transported between the mobile device and the Gateway over the intermediate Wi-Fi link and Internet access network.

VoLGA re-uses this principle by replacing the Wi-Fi access with LTE. From a mobile device point of view there is not much difference between the two access methods because both networks are based on IP. This re-use of GAN was initially explored in the 3GPP Technical Report 23.879⁶ and at the beginning of 2009, the VoLGA Forum was founded to foster the creation of detailed specification documents and subsequent development of the solution.

VoLGA in the Network

Figure 2.1 gives an overview of the basic network setup for VoLGA in the home network as described in the Voice over LTE via Generic Access Stage 2 specification⁷. For an easy start, the optional interfaces that enable explicit quality of service in the LTE network and those required for handing over ongoing voice calls to a circuit switched network are not shown. These are discussed separately further down in the document.

The only new network element introduced is the VoLGA Access Network Controller (VANC), shown in green in the figure below. All other network elements and the interfaces between them already exist and are reused without any modifications.

VoLGA from the LTE Network Point of View

On the LTE side, the VANC connects to the Packet Data Network Gateway (P-GW) via the standard SGi interface. Both signaling and user data traffic (i.e. the voice packets) are transported over this interface. From an LTE core network point of view the VANC looks like any other IP based external node and IP packets exchanged between a wireless device and the VANC are transparently forwarded through the Evolved Packet Core (EPC) network.

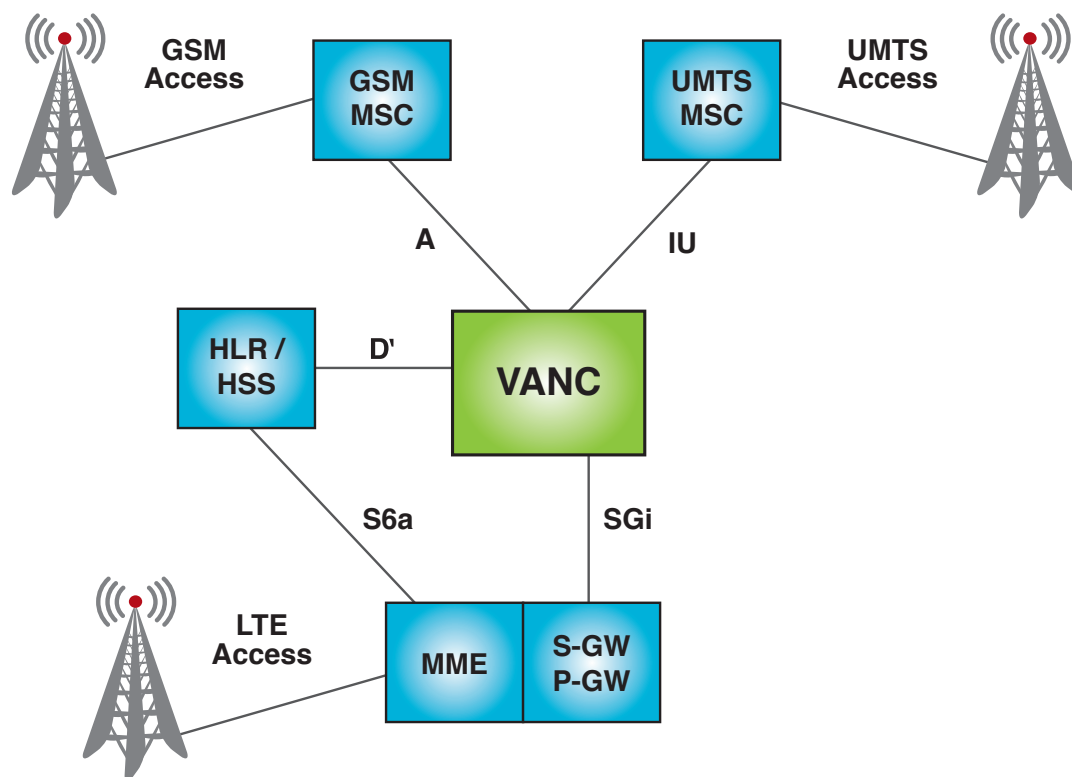

Figure 2.1: Basic VoLGA network setup

VoLGA from the Circuit Switched Network Point of View

On the circuit switched network side the A-interface is used to connect the VANC to a GSM Mobile Switching Center (MSC). The Iu-interface is used to connect the VANC to the UMTS MSC. The VANC thus looks like a GSM Base Station Controller (BSC) to a GSM MSC and like a UMTS Radio Network Controller (RNC) to a UMTS Mobile Switching Center. Which interface is used in practice depends on the requirements of the network operator. As the A and Iu interfaces

are used without any enhancements, the MSCs are not aware that the mobiles are not directly connected via their respective radio networks but instead are connected over LTE. Consequently, no changes are required on these network nodes to support voice, SMS and other services over the LTE network.

Registering to the Network

When a mobile device is switched on and detects an LTE network it first registers with the Mobility Management Entity (MME) over the LTE access network. The MME uses the S6a interface to the Home Location Register / Home Subscriber Server (HLR/HSS) to retrieve the subscriber data required for authenticating and managing the user.

After registering with the LTE network, the mobile then establishes a connection to the VANC. How this is done depends on the VoLGA specific configuration information stored in the mobile device. First, a suitable IP connection needs to be in place. In the home network the default bearer might be used. It is also possible to use a separate bearer and IP address for the purpose. The host name or IP address of the VANC can be pre-provisioned in the mobile device or can be acquired by querying a Dynamic Host Configuration Protocol (DHCP) server in the network over the bearer that was established for VoLGA in the previous step. Once the IP address of the VANC is known, the mobile establishes a secure IPsec tunnel to it over the LTE radio network through the LTE core network and over the SGI interface. During the process the VANC authenticates the user with the help of authentication information stored in the HLR/HSS, which it contacts over the D' interface.

Next, the mobile device registers to the MSC through the secure tunnel and the VANC. The Direct Transfer Application Part (DTAP) protocol is used for this purpose, which is already known from GSM and UMTS. Messages are tunneled transparently between the mobile device and the MSC by all network components involved. Merely the VANC adds information such as a cell-id (2G) or the service area identifier (3G) to the initial registration message as defined in the GSM and UMTS standards respectively.

Outgoing Voice Calls over LTE

Figure 2.2 shows the signaling exchange to establish a mobile originated voice call over LTE. All signaling and control plane messages between the UE and the VANC are transported over the established IPsec tunnel. In a first step, the mobile device sends a message to the VANC to change the connection from idle to dedicated state. Afterwards, a standard GSM/UMTS CM Service Request message is sent to establish a connection to the MSC. When the VANC receives the message it creates a dedicated signaling connection to the MSC over the A- or Iu interface for this user and forwards the message. The MSC then usually authenticates the user and activates ciphering (step 4 and 5 in the figure). Then, the mobile device sends a Setup message in step 6, which contains among other things, the phone number of the person that is to be called. The MSC acknowledges the request with a Call Proceeding message in step 7. As the MSC thinks of the VANC as a GSM Base Station Controller or UMTS Radio Network Controller, it then sends an Assignment Request message to the VANC to request the establishment of a circuit switched bearer channel. The VANC translates this message into an Activate Channel message to the mobile device in step 9 to prepare it for the exchange of IP packets containing voice data. Optionally, quality of service for the voice packets can be ensured by activating a second bearer in the LTE network (step 11). This is further discussed below. Once the mobile device is prepared for the voice data stream, an Assignment Response message is sent back to the MSC in step 13 to signal to it the successful 'pseudo' establishment of a circuit switched channel in the radio network. Once the call has been established with the other party, the MSC sends Alerting and Connect Messages (step 14 and 15) which the mobile device acknowledges. The voice path is then established and the voice conversation can begin.

The voice signal is either transmitted in a 64 kbit/s TDM timeslot on the A-interface in the case of a GSM MSC or via an ATM or IP based data flow in the case of a UMTS MSC. The VANC translates this data stream into IP packets for transmission over the LTE network and vice versa. The standardized Real-time Transfer Protocol (RTP) is used for this purpose and this is the same RTP protocol that is also used by many other voice over IP solutions such as those utilizing SIP and IMS.

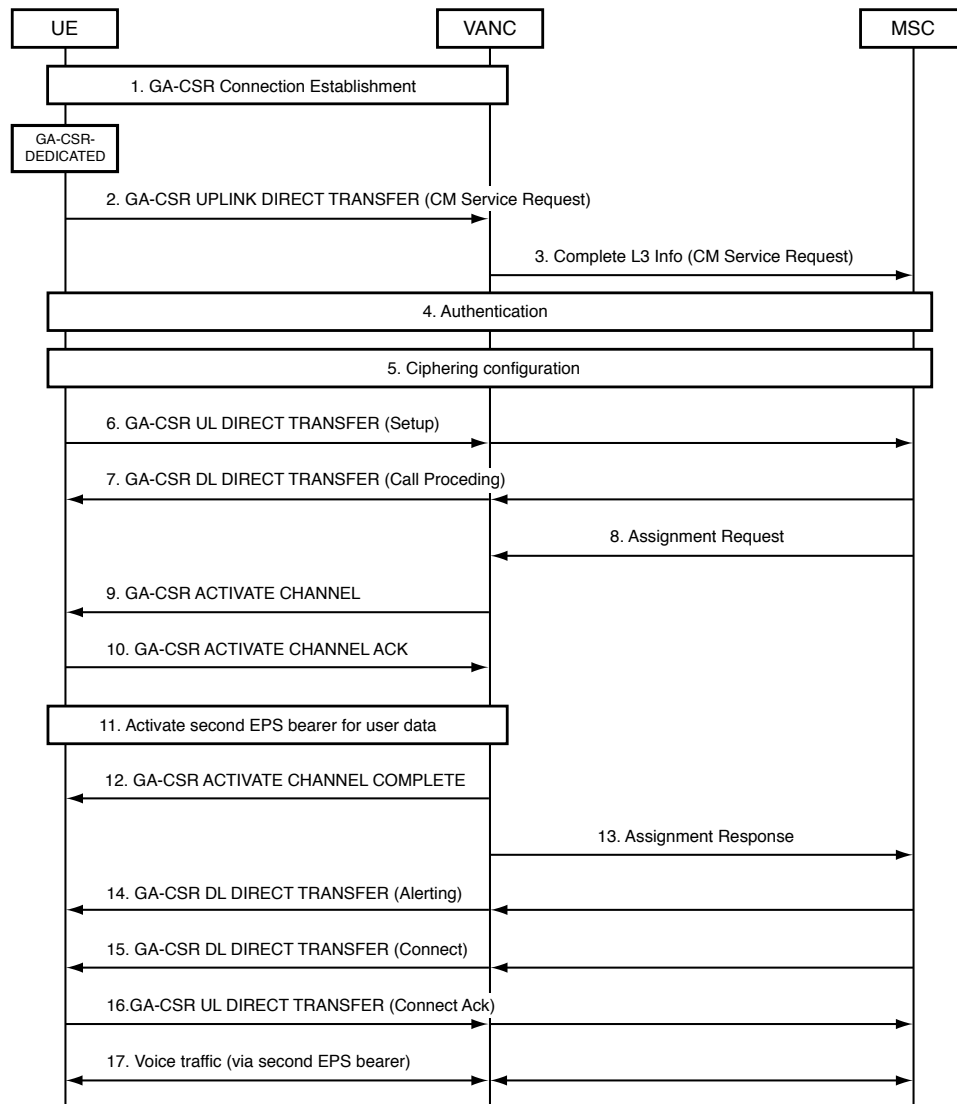

Figure 2.2: Call flow for a mobile originated voice call (VoLGA stage 2 specification, Figure 9.8-1)

Incoming Voice Calls over LTE

Incoming voice calls work in a similar way. As from the MSC point of view no connection is currently established to the mobile device, a standard paging message is sent to the VANC as if it were the BSC or RNC. As the VANC has an established IPsec tunnel to the mobile device it can forward the paging message directly to the mobile. All of this is transparent to the LTE network, i.e. the paging message sent through the IPsec tunnel is not seen and also not needed by the LTE network to find the mobile device.

From the LTE network point of view, the paging message is not visible as it is transported inside an IPsec data packet. If the mobile device's state in the LTE network is 'active', the IP packet is delivered immediately without delay. It could also be that the mobile device has been inactive for some time. As a consequence the physical connection between the network and the mobile device has been released. The device's IP address has been preserved, however, and thus it is still logically present for the network in or around the area of the base station that was last used to communicate with it. This area is referred to as the tracking area. The MME can then re-establish contact to the mobile device by sending an LTE paging message via all base stations of the device's last known tracking area. When the LTE paging message is received by the mobile device it re-establishes radio contact. Afterwards, the IPsec encapsulated packet containing the paging message is delivered to the mobile and the call establishment signaling can commence. The time required for the LTE paging is similar to the time required to page the mobile device in a circuit switched wireless network. Therefore, the call establishment time for a voice call over LTE is similar to that of a GSM or UMTS network.

3 Handover

A very important functionality of VoLGA is its ability to hand over ongoing calls from the LTE network to a GSM or UMTS network when the user leaves the LTE coverage area. In fact, this is one of the most valuable differentiators that network operator supplied voice services have compared to over-the-top VoIP services. Services such as Skype cannot fall back to a circuit switched channel as they are purely based on IP and thus have no means to interact with the radio network.

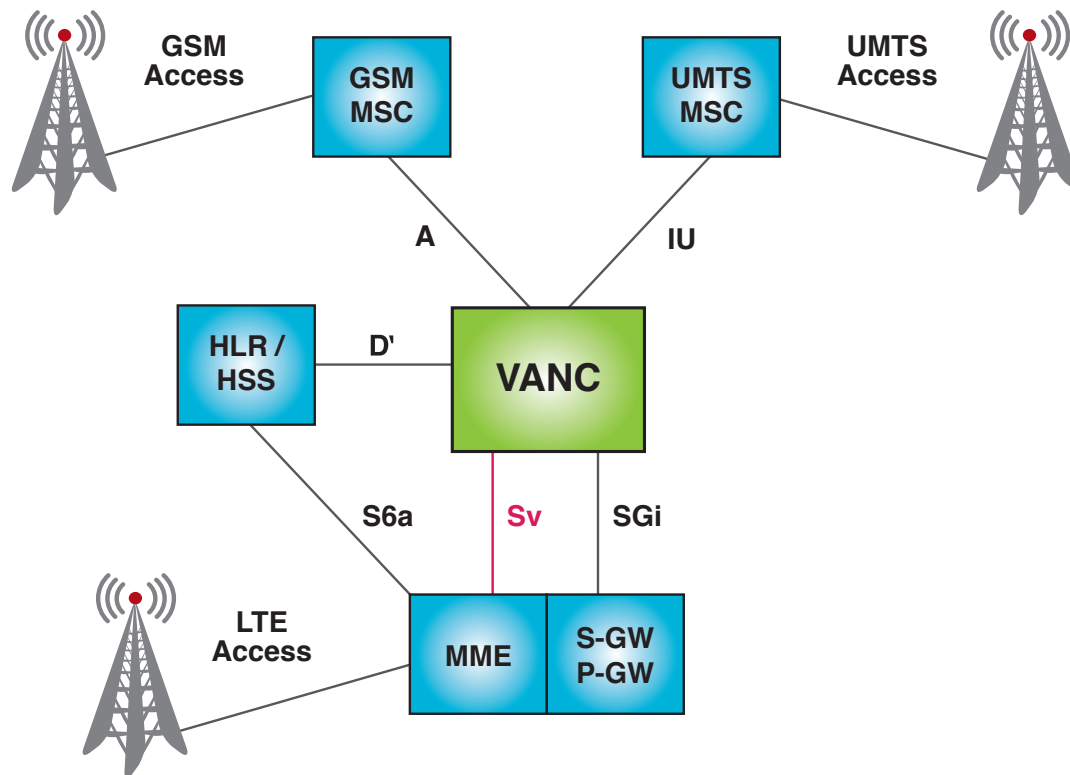

Figure 2.3: The Sv interface used by VoLGA for circuit switched handovers

For VoLGA, handover mechanisms are used which have been initially specified for IMS Single Radio Voice Call Continuity (SR-VCC) in 3GPP TS 23.216⁸. The basic handover steps are as follows:

- When the mobile registers with the LTE network it signals its SR-VCC capability to the MME. The network is thus aware that this procedure needs to be executed when the mobile device is about to leave the LTE coverage area while a bearer is active.
- When the base station (the eNodeB) detects that the mobile device could be better served by a 2G or 3G cell it can instruct the mobile device to measure the signal strength of such neighboring cells. Based on these measurement results or based on pre-configured values, the eNodeB then informs the MME that a handover to a 2G or 3G cell is required.
- The MME in turn informs the VANC about the handover which is about to be made. The message includes information such as the target cell-id and the id of the subscriber for which the handover is to be made. For this purpose, the MME uses the SR-VCC interface Sv as shown in Figure 2.3. In case the message is sent to the VANC for a subscriber that uses IMS instead of VoLGA, it's possible to forward this message unaltered to the MSC. For clarity, this interface is not shown in Figure 2.3.
- In the next step the VANC uses the information it has received from the MME to create a standard GSM or UMTS handover message to the indicated target cell. If the target cell is connected to the same MSC as the VANC, the target cell is prepared for the handover locally and the handover is executed as soon as the cell is ready. From an MSC point of view the handover looks no different from a standard GSM or UMTS handover. In case the target cell is connected to a different MSC, a standard Inter-MSC handover procedure is initiated.

For VoLGA, the MSC does not have to support the new Sv interface as it is terminated in the VANC. Therefore, no modifications are required on the MSC for VoLGA handovers.

4 Quality of Service

Another important VoLGA feature that sets it apart from over the top VoIP applications is the ability to activate network based quality of service measures to ensure that the required bandwidth for the call is reserved throughout the wireless network and especially between the base station and the mobile device. Again, mechanisms and network nodes that have originally been specified for IMS are reused. In a 3GPP wireless network, the Policy Charging Rule Function (PCRF) entity is responsible for approving and distributing quality of service requests from applications hosted in the network to the underlying transport network nodes such as the P-GW, S-GW and the eNodeB (the base station). Figure 2.4 shows how the VANC can request QoS by connecting to the PCRF via the standardized Rx interface.

To activate QoS for a call the VANC contacts the PCRF during step 11 in the call establishment process as shown in Figure 2.2 and requests that packets to and from certain IP addresses and UDP ports be given a higher priority in the network. Based on the subscription profile of the user in the HLR/HSS, the request is granted or denied. If granted, the PCRF establishes a secondary bearer throughout the LTE network and also informs the mobile device. Packets matching the criteria set above are then given a preferential treatment by all network components and also the mobile device as uplink capacity might also be limited.

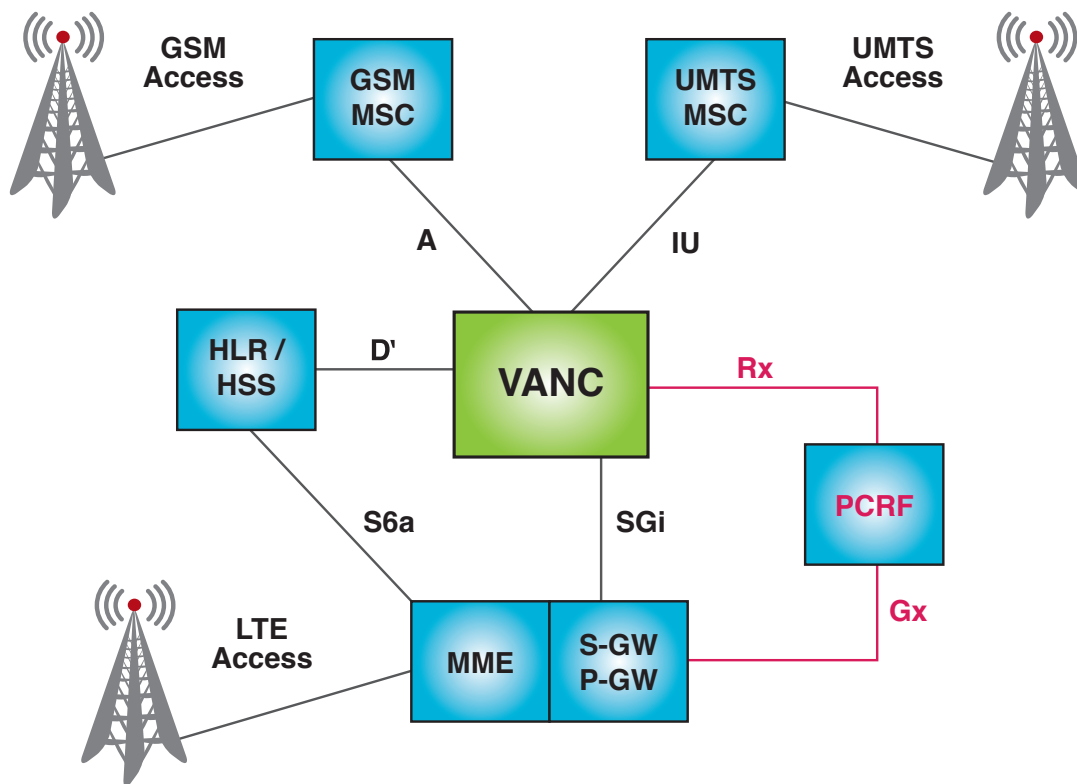

Figure 2.4: Ensuring Quality of Service for the Voice Call with the PCRF

5 International Roaming

When a subscriber roams to a foreign LTE network the VoLGA specification allows for two options:

Local Breakout

The first and preferred scenario is that VoLGA is natively supported in the roaming network. In this case, the mobile uses a VANC and MSC in the visited network. To get the subscriber's subscription information from the HLR / HSS in the home network, interfaces that already exist today for standard international GSM and UMTS roaming are used. For billing, the standard international billing procedure is used.

In a default setup today, a roaming subscriber always contacts a 2G or 3G Gateway GPRS support node (GGSN) in the home network. This is convenient for the user as he doesn't have to change the configuration of his device while roaming. However, this scheme requires that all IP traffic is routed to the subscriber's home network. This is not only very uneconomical but it is also impossible to contact network nodes in the visited network such as a local VANC. For LTE, it is likely that the same scheme is used for many purposes. In this case the gateway node is the home P-GW.

To reach the VANC in the visited network a feature referred to as 'local breakout' is used. It was standardized already in the early UMTS specifications but to this day is used only very little if at all. Local breakout allows the use of a GGSN (in case of GSM and UMTS) or a PGW (in case of LTE) in the visited network and is controlled by using a visited network specific Access Point Name

(APN) which has to be configured in the mobile device. The VoLGA specification mandates a list of networks and associated APNs in the mobile device for that purpose. In addition, a default APN is specified which is used if the foreign network is not in the list.

Once the mobile device has established an IP connection to the P-GW in the visited network, the standard procedures described earlier (e.g. a DHCP lookup) are used to determine the IP address of the VANC in the visited network. For the software of the mobile device this procedure is the same as if the P-GW was in the home network. By using local breakout it is thus very simple to enable international VoLGA roaming.

SMS messages for roaming subscribers are forwarded to the MSC in the visited network to which the subscriber is attached and from there via the VANC to the mobile device. Again, this is a standard roaming procedure. Subscriber originated SMS messages follow the same route in the opposite direction.

Local Breakout

In case the visited network does not support VoLGA natively it is possible to use an APN that establishes a connection to the P-GW in the home network of the subscriber. This is currently not described specifically but the standard would allow for this. As described above, this is what happens today for a standard IP connection for most roamers anyway. There are several disadvantages however:

- The voice packets need to be routed back to the home network. For calls into the home country of the subscriber this is not much of an inconvenience but for calls to the visiting country a loop from the visited country to the home country and back is introduced in the speech path.
- The VANC in the home network and the MME in the visited network might not be able to communicate with each other. As a consequence, handovers between the visited LTE network and a GSM or UMTS network in the foreign country are not possible.
- Emergency calls are not possible in this setup, as a home network MSC is used that can't connect the call to an emergency center in the visited country. It is therefore essential that an automatic fallback is performed to a GSM or UMTS network in the visited network before an emergency call is attempted. This is discussed in more detail in the next section.

Despite these disadvantages it might still be favorable to provide VoLGA services from the home network in visited networks that do not support it natively. This way, it is possible for example to ensure delivery of SMS messages, for example for roaming tariff information or EU mandated bill-shock warning⁹.

6 Emergency Calls

Emergency calls to police, fire departments and medical services is an important feature of wireless networks. In practice the user dials a standardized short code such as 112, 911, etc. A special call setup procedure is then used to ensure that room is made for this call in case the network is overloaded. In some countries, the identity of the cell from which the emergency call was established is forwarded to the emergency center to help locate the person requiring emergency assistance.

VoLGA supports emergency calls as follows:

As the messaging between the mobile device and the MSC is exchanged transparently, emergency calls work the same way over VoLGA as in a 2G or 3G network, i.e. the same messages for call setup are being used. As LTE cell-id's can't be processed by a 2G or 3G MSC, the VANC has to ensure that a proper virtual cell-id representing the LTE macro cell is appended to the initial call setup message.

If a PCRF is used for quality of service in the network, the VANC signals a different priority to it during the emergency call establishment to ensure all IP packets for this call get the highest priority in the network and especially on the radio link. The VANC itself is aware of the emergency situation because the mobile device indicates this through the IPSec tunnel before the actual call establishment messaging. In addition, the VANC can monitor the call setup messaging and despite not altering it, thus becomes aware of the emergency situation.

The VoLGA system can also be configured to instruct the mobile device during initial registration that a fallback to a 2G or 3G network should be made for emergency calls. Some operators might prefer this method, as no extra datafill is required in the network for the localization of the call.

7 Present and Future Alternatives

VoLGA is not the only system designed to deliver voice and SMS services over LTE networks. This chapter quickly summarizes a number of other options, their advantages and their disadvantages compared to VoLGA.

CS Fallback (CSFB)

The approach favored by many 3GPP members as an initial solution for delivering voice and SMS services over LTE is 'circuit switched fallback', which is specified in TS 23.272¹⁰. The idea behind this solution is to use a 2G or 3G network for incoming and outgoing calls, i.e. the mobile has to leave the LTE network for making or accepting voice calls. A more detailed introduction can be found at WirelessMoves¹¹.

From the author's point of view, there are a number of disadvantages to CSFB:

Changing to another network takes time, which has an adverse effect on call setup times. Already today, users perceive mobile call setup times as too long. It is estimated that even in the best case scenario, both mobile originating and mobile terminating call establishment times would increase by at least 1.5 seconds. In many scenarios, it might even be more. From a network point of view a new MSC and SGSN interface is required to signal incoming calls and SMS messages to the MME. This interface, referred to as SGs in the standards, is based on IP and therefore requires new software on network nodes that are delivering the main services today. Some network operators see this as a critical point as they are hesitant to introduce a new and unproven feature on critical infrastructure without an intense testing effort. Also, many network operators have bought MSCs and SGSNs from different vendors, further increasing cost and interoperability testing.

On the positive side, no fallback to a 2G or 3G network is required for delivering SMS messages. However, there currently seem to be a number of open issues, especially around roaming availability and standardization gaps concerning concatenated SMS delivery as indicated in 3GPP discussion paper SP-090429¹².

IMS

A solution, long in the making, is the IP Multimedia Subsystem, or IMS for short. It's core is based on the popular Session Initiation Protocol (SIP) which is widely used in fixed line IP based networks for Voice over IP. For wireless networks, many additions were specified like for example features to handle wireless specific issues such as unreliable radio connections, application servers for external application development, international roaming, scalability, security, etc.

While standardization on IMS has started many years ago, few if any commercial deployments have been undertaken so far due to, among other things, its significant complexity. Given the current state, it is unlikely that an IMS solution is available in the first years of LTE to serve as a voice platform. Therefore, IMS will not be an immediate alternative to VoLGA. An introduction to IMS is given in Chapter 6 of ¹³ and for a very detailed introduction to IMS, ¹⁴is recommended.

The initial concept of IMS was to be an IP platform only, i.e. no ties were specified for services to roam between an IP network and a circuit switched legacy network. Over time, it was recognized that this approach is not suitable for a practical deployment and extensions have been standardized to enable ongoing voice sessions to be handed over between an IP based wireless access network and a circuit switched access network. The latest of these features is Single Radio Voice Call Continuity (SRVCC). As the somewhat long name of the feature implies that only a single radio in the mobile device has to be active on at any one time, even during a handover. This simplifies mobile device development.

3GPP had the foresight to specify SRVCC in an IMS independent manner. Therefore, the VoLGA forum decided to use it as the means to handover VoLGA calls from LTE to GSM or UMTS. As a result, no VoLGA specific features are required in the MSC or SGSN for VoLGA, which is a great plus for deployment in a running network.

Over-the-Top VoIP

Some network operators might also decide to go an entirely different way and offer voice services over LTE with external partners. UK network operator '3', for example, has partnered with Skype¹⁵ to deliver voice services in addition to their own circuit switched services. While their Skype client also uses circuit switched resources for the time being this could change quickly in the future.

There are two technical disadvantages of partnering with external voice service providers, however. The first one is that external voice service providers have no control over quality of service in the wireless network and thus they can't ensure a good quality of experience under all load situations. A potential solution to this issue could be to install logic in the network to ensure quality of service for data streams that are recognized to belong to an external voice service the user has subscribed to. PCRF functionality could be used for this as described earlier but there is no standardized way to offer this yet.

The second problem with Over-the-Top VoIP is that calls can't be handed over to a circuit switched 2G or 3G network when a user leaves the LTE coverage area. Like before, this is because external applications can't be tied into the wireless network infrastructure easily. This is a serious disadvantage, as LTE networks will have an inferior network coverage compared to GSM for many years to come.

8 Summary, Conclusion and Acknowledgments

Advantages

This paper has shown that VoLGA has a number of significant advantages over other Voice over IP solutions for LTE. On the network side, VoLGA does not require updating any of the existing network components, thus ensuring a very quick and smooth market introduction. Instead, all development is concentrated in the VoLGA Access Network Controller (VANC).

In addition, VoLGA enables other circuit switched services from day one without any additional development. One of those is SMS for person to person messaging, a significant revenue generator for mobile network operators. In addition, SMS is also used for updating the configuration of mobile devices and for transmitting mandatory roaming information messages in Europe, both essential services when networks are launched.

On the mobile devices side it is also likely that VoLGA can be developed very quickly, as the already existing GAN protocol stack can be mostly re-used. The only major change in the software is handover handling, as the network based Single Radio Voice Call Continuity (SRVCC) feature will be used.

And finally, VoLGA can also ensure a smooth introduction of global roaming. In case it is supported in the visited network, local breakout allows using the VANC and MSCs in the visited network. For network operators launching LTE as a data only network or only with voice options not supported by a mobile device, it is also possible to use the VANC and the MSCs of the home network.

Disadvantages

The main disadvantages of VoLGA at this point are as follows:

First, it is not fully standardized yet as the stage 3 specification has not yet been finalized. This is expected shortly, however. As it is likely that the stage 3 specification will be based on the equivalent GAN stage 3 specification, vendors can already develop products without waiting for a final stage 3 specification being published by the VoLGA forum.

Second, VoLGA is currently not a work item in 3GPP. There are probably several reasons for this, one being that the number of features for Release 9 was already high and most members wanted to ensure the tight completion deadline was met which would have been more difficult with an extended project scope. Some opposition for the work item has also been met from 3GPP participants which favor other Voice over LTE solutions. The situation is thus similar to the situation during the early times of GAN, which was also first developed outside 3GPP before it was included as a specification later-on.

Conclusion

From a complexity point of view, VoLGA makes it very simple to leverage existing 2G and 3G circuit switched equipment in live networks for LTE. This is especially because no software enhancements are required on existing network nodes.

Due to this and other advantages of VoLGA described above, the author of this paper believes that VoLGA has the chance to become a widespread Voice over LTE solution and will ensure that two of the main revenue generators for network operators, voice calls and SMS, will be available in LTE networks very early on.

Acknowledgements

The author would like to thank 3GPP for their very open policy, i.e. releasing all discussion documents, reports and specifications on their website in a very timely manner. This greatly simplifies research on mobile topics and fosters faster development. In addition, the author would like to thank Kineto Wireless¹⁶ for their support and for sponsoring this whitepaper.

9 List of Abbreviations For Easy Reference

2G	2 nd generation wireless networks; refers to GSM networks in this paper.
3G	3 rd generation wireless networks; refers to UMTS networks in this paper.
3GPP	3 rd Generation Partnership Project; refers to the organization in charge of GSM, UMTS and LTE standards.
APN	Access Point Name; An identifier given to the network when a packet session is started so the network can contact the desired gateway node to establish an Internet connection.
BSC	Base Station Controller; A radio network element in 2G networks that controls a number of base stations.
CSFB	Circuit Switched Fallback; A method to fall back from LTE to a 2G or 3G network for voice calls.
DHCP	Dynamic Host Configuration Protocol; Used in IP networks to assign an IP address, default gateway IP address and other network based parameters to a device when it connects to the network.
eNodeB	Enhanced NodeB; A LTE radio base station.
GAN	Generic Access Network; A method to use a GSM or UMTS core network over Wi-Fi (WLAN) access.
GANC	GAN Controller: The network element between the Wi-Fi access and backhaul network on one side and the mobile core network on the other.
GSM	Global System for Mobile communication.
HLR / HSS	Home Location Register / Home Subscriber Server; The database in the mobile core network where subscriber information is stored IMS IP Multimedia Subsystem; Supporting structure for next generation multimedia applications in fixed and wireless networks.
IP	Internet Protocol.
LTE	Long Term Evolution; Commonly used acronym used for network beyond 3G. Technically the use of this term, however, is not quite correct as it was only a placeholder for a new radio network acronym. The correct terms are E-UTRAN (Enhanced UMTS Terrestrial Radio Access Network) and SAE (System Architecture Evolution).
MME	Mobility Management Entity; The node in the network responsible for managing the mobility of registered subscribers in the network.
MSC	Mobile Switching Center; A circuit switched core network node for voice messaging. Also forwards SMS messages between the mobile subscriber and the SMS Service Center.

PCRF	Policy Charging Rule Function; The node in the network which enforces quality of service per request of higher layer applications such as VoLGA, IMS and others.
QoS	Quality of Service; Mechanisms to ensure that IP packets for applications are delivered in a timely manner for applications such as VoIP which are very intolerant to packet delay and jitter.
RNC	Radio Network Controller. UMTS radio network element controlling a number of base stations.
SMS	Short Message Service.
SRVCC	Single Radio Voice Call Continuity; Used for example in LTE to hand over a VoIP call to a circuit switched network that does not support VoIP.
TDM	Time Division Multiplexing; Legacy method still widely used today in wireless networks to transport voice calls.
UMTS	Universal Mobile Telecommunication System.
VANC	VoLGA Access Network Controller; The network element required by VoLGA which connects the circuit switched MSC to the packet switched LTE Network.
VoIP	Voice over IP; Methods to transport voice calls over IP networks.
VoLGA	Voice over LTE via Generic Access.
Wi-Fi	Wireless Fidelity; Sometimes also referred to as Wireless LAN or WLAN.

[1] The Third Generation Partnership Project - <http://www.3gpp.org>

[2] The VoLGA Forum - <http://www.VOLGA-forum.com/>

[3] HTC Shadow II - <http://www.i4u.com/article18412.html>

[4] The Motorola Morrison - <http://umatoday.blogspot.com/2009/08/uncovering-motorolamorrison.html>

[5] GAN device manufacturers:
http://en.wikipedia.org/wiki/Generic_access_network#Devices (version from 30 July 2009)

[6] 3GPP TR 23.879 - Study on Circuit Switched (CS) domain services over evolved Packet Switched (PS) access; Stage 2, 3GPP Release 8

[7] Voice over LTE via Generic Access; Stage 2 Specification; Phase 1 - Available at the VoLGA Forum website

[8] 3GPP TS 23.216 - Single Radio Voice Call Continuity (SRVCC); Stage 2

- [9] Bill Shock Warning by March 2010 - http://ec.europa.eu/information_society/activities/roaming/regulation/index_en.htm#new_rules
- [10] 3GPP TS 23.272 - Circuit Switched (CS) fallback in Evolved Packet System (EPS); Stage 2
- [11] Introduction to CS Fallback - http://mobilesociety.typepad.com/mobile_life/2008/09/lteand-the-voice-gap-cs-fallback.html
- [12] 3GPP discussion paper SP-090429 - http://ftp.3gpp.org/ftp/tsg_sa/TSG_SA/TSGS_44/Docs/SP-090429.zip
- [13] Martin Sauter, Beyond 3G - Bringing Networks, Terminals and the Web Together: LTE, WiMAX, IMS, 4G Devices and the Mobile Web 2.0, 2009, ISBN: 978-0470751886
- [14] Camarillo et al, The 3G IP Multimedia Subsystem (IMS): Merging the Internet and the Cellular Worlds, 2008, ISBN: 978-0470516621
- [15] 3UK and Skype partnership - <http://www.totaltele.com/view.aspx?ID=445057>
- [16] Kineto Wireless - <http://www.kineto.com/>